

# — Press Book

What we do.

Energy efficiency in tissue making.



EDITION 7

 **TOSCOTEC**  
A Voith company

# PRESS BOOK

---



---

## EDITION 7

Dear customers,

this new edition testifies to Toscotec's unfailing commitment to you.

In difficult times, such as those we are still living through, we do not make excuses, and we continue to aim for excellence.

We are also reminded of the importance of joining forces and working together towards our common targets. Even more so today, we believe that the value of partnership is our guiding light, and our attitude.



Alessandro Mennucci  
Chief Executive Officer of Toscotec

# CONTENT

6		Our values: the 5P
8		YOU-US Customer testimonials
12		Toscotec to supply two major rebuilds in Africa and Western Europe on a turnkey basis
14		Toscotec to deliver a Steel Yankee Dryer to C. Y. P. Del R. S.A., Colombia
16		Toscotec exceeds performance goal on wet end rebuild at Papeterie Le Bourray
18	PAPER & BOARD	Toscotec's rebuild achieves production increase at Skjern Paper, Denmark
23		Toscotec-Rebuilt Hoods yield double-digit consumption reduction at Wepa Giershagen
26		Toscotec to supply three tissue rebuild projects
28		Toscotec successfully completes a dryer section rebuild at Aviretta in Germany
30		Toscotec to supply an AHEAD 2.2S tissue line to Europap Tezol Kağıt in Turkey
32	<b>PRODUCT FOCUS</b>	<b>Toscotec introduces TT Defender for effective protection of steel Yankee dryer</b>
36	PAPER & BOARD	JSC Yarpaper successfully starts up PM1 after major rebuild by Toscotec
40		Toscotec to supply two TADVISION machines to Hengan Group in China
42		MEPCO signs with Toscotec. Toscotec to supply tissue machine for MEPCO's new tissue mill in KAEC
44	<b>PRODUCT FOCUS</b>	<b>Toscotec launches new YES-CONNECT-VISION AR system for effective remote service</b>
46		Lucart validates Toscotec's TT Defender ability to increase Yankee efficiency
50	PAPER & BOARD	Toscotec finalizes a drying section rebuild at Cartiera San Giorgio, Italy
52		Toscotec-supplied turnkey tissue line achieves top speed at Paloma
56	PAPER & BOARD	Toscotec accomplishes a dryer section rebuild at Cartiera di Ferrara, Italy
58		Toscotec's new tissue line starts up at Thai C.A.S. Paper Mill
61		Sofidel attains high efficiency and premium quality on Toscotec's lines
64	<b>PRODUCT FOCUS P&amp;B</b>	<b>Toscotec to supply a wet end rebuild to Dunn Paper in Michigan</b>
66	<b>PRODUCT FOCUS</b>	<b>Toscotec steps up Yankee hood efficiency with TT Drying Equilibrium</b>
70	<b>PRODUCT FOCUS</b>	<b>Toscotec introduces new shoe press generation design for tissue</b>

- 72 Toscotec to supply an AHEAD 2.2S tissue line to Saudi Paper Group
- 75 Toscotec to supply a TT SYD Steel Yankee Dryer to Mirae Paper
- 78 Toscotec to supply an AHEAD 2.2L tissue line to GrandBay Papelera Internacional
- 80 Sappi taps Toscotec for TT SYD Steel Yankee Dryer
- 84 Toscotec to supply a turnkey tissue line to Vajda Papír in Hungary



# OUR VALUES —

At Toscotec, we have our principles straight. What inspires us in the cooperation with our customers and the execution of all our projects is a combination of five elements: we call it the “5 P” value system and we conceive it in this precise order:



# THE 5P

## People

Everyone at Toscotec is committed to helping you achieve your goals and making your job easier. All our people are focused on you, and the company is built on its people, and focuses on giving them the resources they need to thrive. We are flexible-minded, fast-thinkers and team workers. Customers hold a seat of honor on our team.

## Product

Our technology is reliable, energy-efficient and tailor-made to your needs. We provide advanced solutions for structured, textured and dry-crepe paper, and we assist you in the project planning, installation, training, start-up, and optimization. We constantly develop and upgrade our technology to allow you to be one jump ahead in the market.

## Performance

We pride ourselves on achieving the maximum production and the best energy saving results on every project we do. When we engineer our machines, we focus on the production increase and energy consumption reduction you aim for. We make sure you always have our latest solutions, because customers are our preferred voice to testify to the success of our technology.

## Partnership

We listen carefully because your requests are our starting point. When we get into a project and are required to make fast decisions, our partnership with you comes first, always. Nothing is more important to us than achieving our common goal. This is when we really demonstrate just how customer-dedicated we are.

## Price

We deliver state-of-the-art technology, skilled technical teams, and rigorous time management for your projects: high value at a fair price.

# YOU —

## Customer testimonials

The relationship with our customers is very important to us  
and we are always happy to receive feedback from them.  
We thought the best introduction would be through their voices.  
Here is what they're saying about us.



## ON TECHNOLOGICAL EXCELLENCE AND ENERGY EFFICIENCY

### **GRANDBAY GROUP, GUATEMALA**

**Alberto Matos Project Engineering Manager**

*"We now have high expectations on the performance of their AHEAD tissue line, first and foremost in terms of energy efficiency. This project represents a milestone of our growth strategy; we trust that Toscotec's expertise and state-of-the-art technology will enable us to achieve our targets."*

### **SAPPI, SOUTH AFRICA**

**Nash Ayer, Procurement Manager**

*"We decided on Toscotec because they met our foremost selection criteria of high energy efficiency and reliability. The choice of leading-edge technology such as TT SYD that will increase the energy efficiency of our tissue line is part of our strong commitment to climate-smart solutions."*

### **SAUDI PAPER GROUP, SAUDI ARABIA**

**Youssef Abdel Hamid Abdel Aziz El Bishry, CEO**

*"Toscotec's AHEAD tissue machine will increase SPG's production capacity. We believe in the importance of equipping ourselves with leading-edge technology that will allow us to achieve our production targets with optimal performance and energy efficiency, delivering the highest quality to our customers."*

### **MIRAE PAPER, SOUTH KOREA**

**Yeong Rok Lee, Production Manager**

*"[Toscotec's] steel Yankee on PM3 has been operating efficiently for over 8 years, allowing us to reduce our thermal energy consumption by a significant amount. We expect the new Yankee on PM2 to be as reliable and to deliver even higher performances, considered the design upgrades that Toscotec has implemented on their TT SYD since our first installation."*

### **HENGAN GROUP, CHINA**

**Hui Lin Chit, CEO**

*"Hengan always pursues innovation and top quality products; as a result, it leads the development of the Chinese tissue and hygiene market. After scrupulous evaluation, we selected Toscotec as the partner to support us to achieve our new target."*

### **MEPCO, SAUDI ARABIA**

**Sami Safran, CEO**

*"Signing the machinery supply contract with Toscotec puts us at comfort about the product quality and efficiency, which are essential to position our products perfectly in the market."*

### **CARTONES Y PAPELES DEL RISARALDA, COLOMBIA**

**C. Y. P. Del R. S.A.**

*"We chose TT SYD based on its great reliability and superior energy efficiency. When we selected the supplier for this rebuild, we were looking for the best solution to increase our production capacity. Toscotec customized the equipment specifically for our needs and offered us the possibility of reducing our manufacturing cost as well."*

## ON TURNKEY SUPPLY & PROJECT MANAGEMENT

### **SOFIDEL AMERICA, USA**

**Simone Capuano, Executive VP, Operations & Supply Chain**

*"Even though we had to face unpredictable and complicated situations, Toscotec's flexibility, contribution and spirit of collaboration have never been lacking. We appreciated their dedication and problem-solving skills."*

### **VAJDA PAPIR, HUNGARY**

**Attila Vajda, Owner and Managing Director**

*"We found in Toscotec the right partner to realize our expansion strategy according to plan. Based on their extensive experience with turnkey operations, our confidence in Toscotec's ability to successfully complete complex tissue projects on a tight timeframe was a key factor in our decision."*

### **C.A.S. PAPER MILL, THAILAND**

**Torpong Thongcharoen, Managing Director**

*"Throughout the entire project, including the hardest times during the pandemic, we always had a very good cooperation with Toscotec, who proved to be the experienced and skilled supplier we expected, managing the project with great flexibility and supporting us all the way to our target."*

### **AVIRETTA, GERMANY**

**Thomas Reibelt, Project Manager**

*"The cooperation with Toscotec was very good right from the beginning. We are happy to have worked with a supplier who has such a significant experience with rebuilds. The new TT SteelDryers have been performing very well since start-up, with good results in drying capacity and energy efficiency."*

### **JSC YARPAPER, RUSSIA**

**Igor Noskov, Project Manager**

*"We successfully completed a major rebuilding operation on our paper machine in difficult times during Covid-19. We have expanded our range of high quality containerboard papers to 90-175 gsm and have increased our reel width to 2,500 mm."*

### **PAPETERIE LE BOURRAY, FRANCE**

**Alexandre Pappalardo, Head of Maintenance & TN**

*"We are very satisfied with the outcome of the project. Toscotec respected the time limits of machine shutdown and the new TT Headbox delivered on the performance targets. The restrictions in place during lockdown required extra efforts from both companies, but our good cooperation made it possible to complete the rebuild on schedule."*

### **CARTIERA SAN GIORGIO, ITALY**

**Alessandro Ardinghi, Owner**

*"The targets of this rebuild have been fully accomplished. We have known Toscotec for many years, and we are happy with how they managed the project and delivered on the results we expected."*

### **CARTIERA DI FERRARA, ITALY**

**Alessandro Castelletti, Mill Manager**

*"Toscotec executed the rebuild with competence and according to the agreed time plan. We boosted PM1's operating speed because of the increased drying capacity of our new dryer section."*

# US

## ON PRODUCT QUALITY

### **SOFIDEL AMERICA, USA**

**Simone Capuano, Executive VP, Operations & Supply Chain**

*"The AHEAD 2.0L machines used on our lines represent a tried and tested technology that did not require any fine-tuning.[...] The quality standard is high and meets our customers' requirements and, at the same time, it allows us to achieve excellent performances at the plant in terms of energy efficiency and optimization of raw material use."*

### **SLOVAK HYGIENIC PAPER GROUP, SLOVAKIA**

**Stevan Lomic, Technical Director**

*"We are manufacturing premium quality tissue and are very happy with product quality. Toscotec has shown extreme flexibility in these challenging times and has completed the project with great professionalism."*

### **EUROPAP TEZOL KAĞIT, TURKEY**

**Ersin Tezol, CEO**

*"Our production capacity expansion required the most advanced technology at a cost-attractive price. Toscotec's technology was the best choice to meet the strict environmental requirements of our company and the high quality standards of our super-prime brands, especially for softness and hand feel."*

### **DUNN PAPER, USA**

**Steve Michalko, Manufacturing Director**

*"By upgrading to a Toscotec dilution profiled headbox in addition to their screening and water system improvements, we will improve the uniformity and formation of our base sheet, increasing our capability to meet current and future customer requirements."*

# Toscotec to supply two major rebuilds in Africa and Western Europe on a turnkey basis

Toscotec will rebuild two tissue machines in Western Europe and Africa for a leading tissue manufacturer that remains confidential. The projects are on a turnkey basis and are scheduled for completion in 2021.

For the project in Europe, Toscotec will supply the tissue machine's broke line and pope reel section, and its newly designed OPTIMA slitter rewinder, which ensures the preservation of tissue quality and high winding efficiency.

The supply of the project in Africa includes a modification into crescent former configuration, which will replace the existing machine's forming and felt sections.

The provision of engineering design, dismantling operations, erection, commissioning, start-up, and training services, ensures a full-on turnkey supply for the rebuilds.

Toscotec further strengthens its position as leading supplier of tissue rebuilds, building on its substantial expertise in customizing its design to the mill's requirements, supplying turnkey packages, and delivering on the tight schedule of machine shutdown periods.



**Gabriele Romanini, Toscotec Sales Manager**, comments: "The rebuild market is key to Toscotec, because it allows us to do what we do best, that is tailoring the machine configuration and our entire design to the specific needs of the customer, optimize their production to

achieve the maximum possible capacity and energy efficiency. These new projects are no exception. Today, we are still seeing an untapped potential for rebuilds, with producers looking into increasing the efficiency of their older machines."

# Toscotec to deliver a Steel Yankee Dryer to C. Y. P. Del R. S.A., Colombia

Toscotec will supply a second-generation TT SYD Steel Yankee Dryer to the Colombian tissue manufacturer Cartones Y Papeles Del Risaralda. The new TT SYD will replace a cast iron Yankee on PM1 at its Risaralda mill in Western Colombia.

Toscotec's Steel Yankee dryer will increase PM1's production capacity, while reducing its overall specific consumptions through a substantial reduction of the hoods' drying contribution.

The TT SYD has a 3,200 mm diameter, a face length of 2,920 mm and it features Toscotec's patented deckle insulation system, which ensures high thermal

energy efficiency and maximum safety. The scope also includes the steam and condensate removal system, steam joints, bearings and housings. Toscotec will deliver a complete service package including engineering, erection supervision, onsite training, commissioning and start-up assistance.

**C. Y. P. Del R. S.A.**, said, "This investment aims at increasing the effectiveness of our operations. We chose TT SYD based on its great reliability and superior energy efficiency. When we selected the supplier for this rebuild, we were looking for the best solution to increase our production capacity. Toscotec customized the



equipment specifically for our needs and offered us the possibility of reducing our manufacturing cost as well. This winning combination represents a key asset to sustain our growth.”

**Gabriele Romanini, Sales Manager at Toscotec**, said, “We are happy to begin this cooperation with Cartones Y Papeles Del Risaralda. We are confident that TT SYD will meet their expectations in terms of superior drying capacity and energy efficiency, providing them with a competitive advantage in the market.”

Toscotec is the global market leader of Steel Yankee Dryers.

Over 200 TT SYDs are currently operating all over the world, contributing to the build-up of a substantial database of different operating conditions, which drive and advance Toscotec’s expert services and continuous engineering progress on steel Yankee dryers.

# Toscotec exceeds performance goal on wet end rebuild at Papeterie Le Bourray

In June 2020, Toscotec successfully rebuilt the approach flow and wet end of PM4 at Papeterie Le Bourray in Saint-Mars-la-Brière, France. After two months of stable production, PM4 exceeded the performance targets relating to the improvement of sheet formation quality and cross direction basis weight profile. After the rebuild, the operating speed of PM4 increased by up to 10%. The project included a new fan pump and a fully hydraulic TT Headbox. Toscotec also supplied a complete service package, comprising detailed engineering, dismantling operations, erection, commissioning, start-up supervision, and training.

Through the joint effort of Toscotec and Papeterie Le Bourray, the project pushed ahead during the Covid-19 lockdown in France and Italy, and it was executed according to schedule.

**Alexandre Pappalardo, Head of Maintenance & TN at Papeterie Le Bourray**, says, "We are very satisfied with the outcome of the project. Toscotec respected the time limits of machine shutdown and the new TT Headbox delivered on the performance targets. The restrictions in place during lockdown required extra efforts from both companies, but our good cooperation made it possible to complete the rebuild on schedule."



**Andrea Paganucci, Project Manager at Toscotec,** says, "Papeterie Le Bourray provided Toscotec Service team with the best possible working conditions during lockdown. We were united by a common determination to achieve the project targets and we succeeded. The new TT Headbox features a tailor-made design that allows the mill to operate in the current Tisco Former configuration but also in Crescent Former configuration in the future."

**TT Headbox-SLT**



# — Toscotec's rebuild achieves production increase at Skjern Paper, Denmark

Skjern Paper is Denmark's only paper mill. Founded in 1965, it is situated in Skjern, West Jutland. Since 2005, the ownership majority has been held by Buur Invest A/S, a Danish privately-owned investment company. The mill's current annual capacity is 75,000 tonnes, including a range of products - coreboard, grey and blueliner, greyboard and sheets - produced from 100% recycled fibres. Skjern Paper is strongly export-oriented, with over 90% of its production sold to packaging and paper businesses in Europe.

In the third quarter of 2019, Toscotec carried out a complete rebuild of its PM1 dryer section, delivering 19 TT SteelDryers. The scope of supply was on a turnkey basis, including dismantling operations, erection, commissioning and start-up.

In this interview, **Kurt Larsen, Project Engineer at Skjern Paper**, shares his views on the main aspects of the rebuild and his overall evaluation.

**In 2019, Skjern Paper selected Toscotec to rebuild its PM1. Why did you decide to make this investment? And why did you choose Toscotec?**

The main driver for the investment was the need to increase our dryer capacity. PM1 started producing at Skjern in 1967, but it was a second-hand machine, and some of its cast iron dryers dated back to the mid-1940s, some even all the way back to 1927! In order to overcome our drying capacity limits, we decided to install steel cylinders of bigger diameter, operating at a much higher steam pressure (10 barg), new frame and drives that could reach a higher speed. Toscotec's new dryer section can achieve 800 m/min, which is double the maximum speed we had before.

Secondly, we chose steel dryers against cast iron, because of their higher heat transfer efficiency and better safety. In terms of safety, steel cans are definitely a much better choice.

Among the suppliers we evaluated, Toscotec proved to have the most

substantial experience in the design, manufacturing, operation and maintenance of steel dryers.

TT SteelDryers have an incredible number of references around the world and they are manufactured internally by Toscotec. This meant we could have one single supplier for the whole dryer section, which solves the problem of grey zones in-between different manufacturers, which would save us a lot of headaches in the end. Skjern considered this aspect a great added value.

**Focusing on the rebuild itself, was the project delivered on schedule? How do you evaluate its overall management?**

The project was completed on schedule. Other prospective suppliers had foreseen a much longer shutdown period, but Toscotec implemented the whole rebuild within a shutdown period of only 11 days, including dismantling the old equipment and erection of the new dryer section and hood. This timeline was key for us, because bringing the production to a complete stop makes it tough for us to be the flexible supplier we want to be.







Overall, the project management was very well executed. We had committed and competent people at our disposal, and we got all the support we needed on time.

**What have you achieved with this rebuild?**

First of all, we have registered a production increase of more than 11% so far, but we expect to achieve even more after removing the bottlenecks we still have in the wet-end and press section. Secondly, the rebuild lifted the speed limit we had, allowing us to increase the machine speed, particularly for lower grammages.

**What can you tell us about the erection, commissioning and start-up?**

The erection was very efficient. We were working 24/7 under safe conditions, without any injuries. Start-up went very smoothly, with a delay of only one day, which was not caused by Toscotec. We are very satisfied with the onsite implementation of the rebuild.

**How would you describe the cooperation with Toscotec?**

We had very good cooperation with Toscotec. They were attentive to our needs and committed to meet them in the best possible way. If during the erection we had an extra job for them to do or they needed something from us, we helped each other, so that the work was flowing really well. They proved to be very flexible and cooperative. For example, they lent out several people for a few days to help finish up some pipe work. They were working with us towards a shared objective and did not back out when we needed extra help. This is very important to a small mill such as ours, because we have limited resources and therefore we appreciate a supplier who is prepared to go the extra mile to get the job done.



**YOUR NEEDS ————— OUR SOLUTIONS**

# — TOSCOTEC-REBUILT HOODS YIELD DOUBLE-DIGIT CONSUMPTION REDUCTION AT WEPA GIERSHAGEN

Wepa Group is one of the largest tissue manufacturers in Europe, with 13 sites, 21 paper machines, a production of approx. 780,000 t/year, and a positive annual growth trend. Since 2002, Toscotec and Wepa's cooperation has been particularly strong at Wepa Marsberg-Giershagen, where Toscotec supplied a new tissue line on a turnkey basis, completely rebuilt PM5 in two different steps and installed new hoods on other two existing machines, with the result that all tissue machines at the mill are now equipped with TT Hoods.

### PM4 and PM7 Hood rebuilds: Consumption reduction & Speed increase

In order to evaluate the return on the investment, it is always interesting to compare the efficiency of the equipment – consumption and performance - before and after the rebuild. This comparison is particularly clear if we look at PM4 and PM7, where the modification involved only the hoods and the air system. After the installation of TT Hood on PM4, the mill achieved a 12.5% reduction in gas consumption and 50 mpm increase in machine speed. The results on PM7 were similar, with a 13.3% reduction in gas consumption and 50 mpm increase in speed.

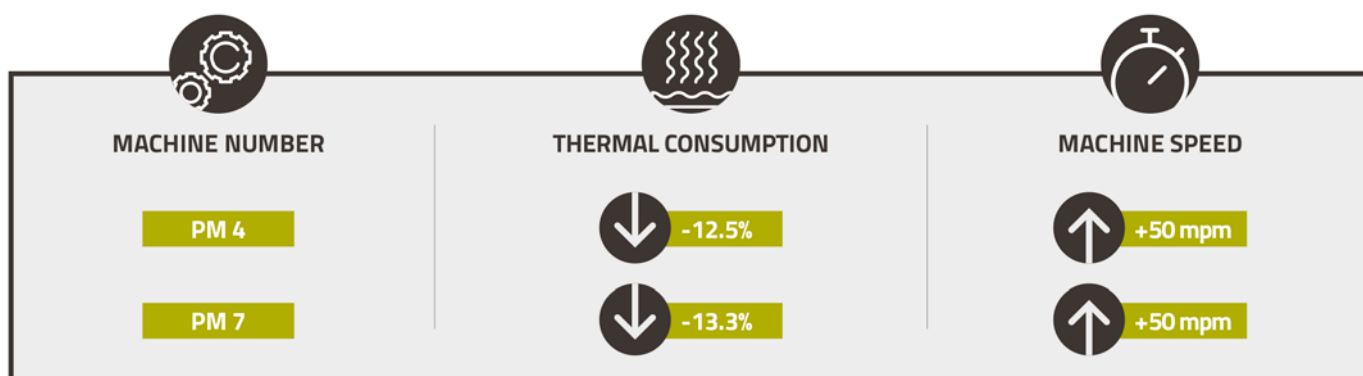

Fig. 1: Results of hood rebuilds on PM4 and PM7.

In general terms, for a tissue machine that produces 30,000 t/y with a thermal consumption of 1.3 MWh/t, 10% of drying energy savings equals a cost reduction of approximately 4 €/t, i.e. 120,000 €/y. Additional savings coming from electrical load reduction and machine speed increase must also be considered.

The above figures offer a clear picture of the potential benefits coming from the use of fully updated equipment including state-of-the-art devices dedicated to:

- Energy saving: complete heat recovery chains for steam generation, air and water heating
- Hoods regulation: automatic balancing system
- Pollutants control: burner management system, burner control and fine-tuning.



### **TT Hoods: customized technology for the highest reliability**

TT Hoods are entirely custom-made, in order to meet the needs of the paper machine. At WEPA Giershagen, Toscotec calculated the best combination of the open area, hole diameter, and hole pattern to achieve top performance and efficiency.

TT Hoods are designed and manufactured at Toscotec's headquarters in Lucca, where its engineers and workers have more than 20 years of experience in hoods and air systems. This expertise guarantees the reliability and the constant improvement of their design and performances.

### **The art of project management in rebuild projects**

Finally, time schedule is always essential in rebuild activities. Wepa Giershagen required Toscotec to schedule every phase of the project, allocating the right resources and time, in order to guarantee an accurate paper-to-paper machine shutdown period. On Wepa Giershagen PM7 for example, the scheduled paper-to-paper shutdown was of 360 hours. The entire work was completed and tested in only 332 hours, i.e. 28 hours ahead of schedule.

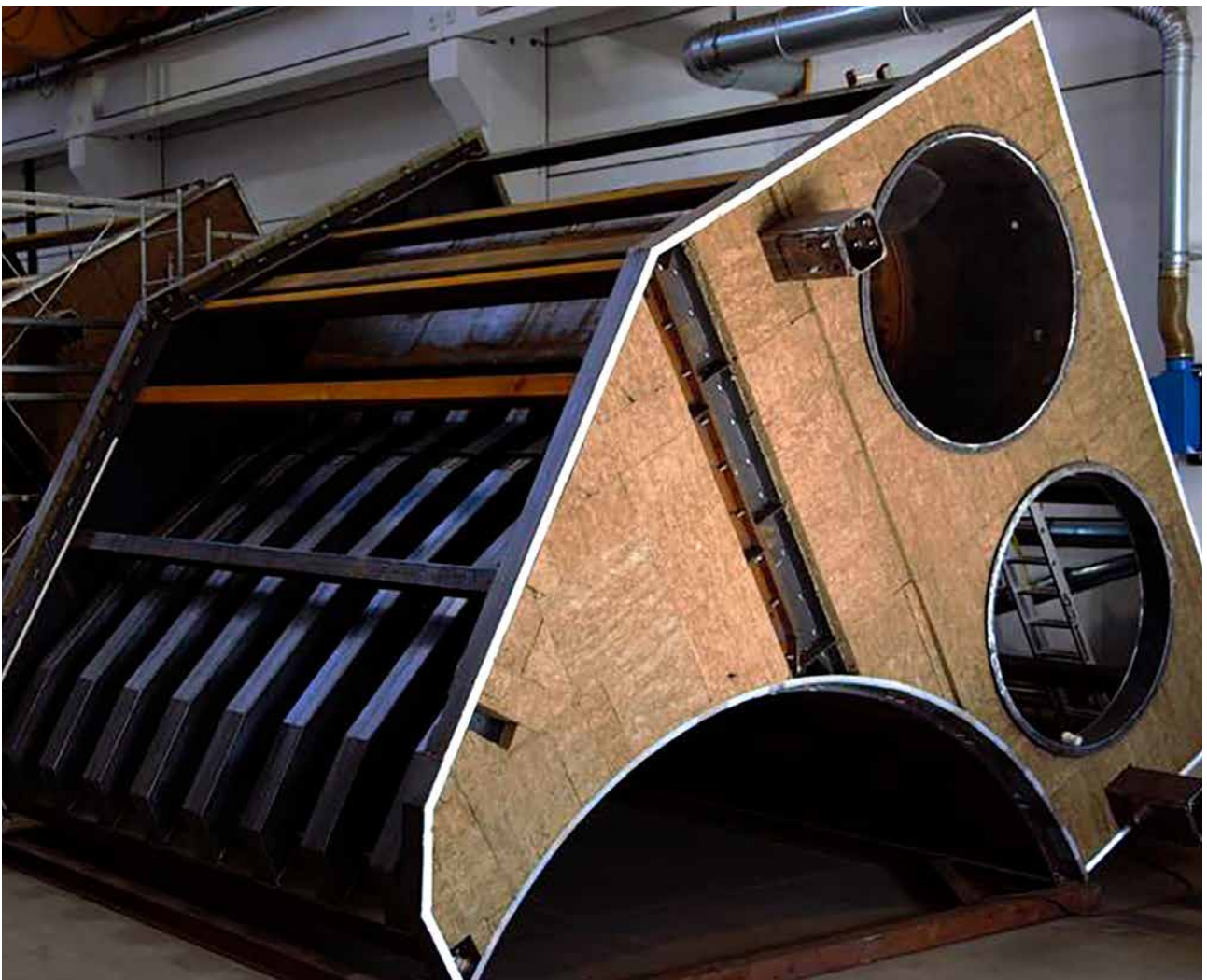

# Toscotec to supply three tissue rebuild projects

Toscotec will deliver three tissue machine rebuilds located at different mills to a confidential global producer.

Toscotec will rebuild the drying sections of two tissue machines, as well as the wet end and winding sections of another machine. The drying section rebuilds include the supply of two Toscotec's third-generation-design TT SYD Steel Yankee Dryers, steam and condensate systems, and high efficiency TT Hoods, including one newly optimized combustion system. The energy efficiency given by the integration of the steel Yankee and the hoods will result in a significant reduction of the tissue machines' thermal consumption.

The other project requires the modification of the approach flow and fiber recovery systems and the complete

rebuild of the machine's wire and pope reel sections.

The provision of expert services, including engineering, dismantling of old equipment, erection, commissioning, start-up, and training, ensures a complete package for the rebuilds.

Since the start-up of its first TT SYD in 2000, Toscotec is the forerunner and world leading manufacturer of Steel Yankee Dryers boasting close to 230 TT SYDs sold and over 200 currently operating in five continents.

These two new TT SYDs will replace the mills' existing Yankee dryers. Toscotec holds the record as the manufacturer who supplied all of the SYD replacements that took place in Europe to date.



**Riccardo Gennai, Toscotec Sales Manager**, says: "We take pride in the continuous evolution of TT SYD. Toscotec started up the first steel Yankee dryer in the tissue industry. TT SYD's third-generation design enhances the machine's drying performance and energy efficiency to a degree that it really makes us stand out in the market."

# Toscotec successfully completes a dryer section rebuild at Aviretta in Germany

Toscotec successfully completed a post dryer section rebuild at German containerboard producer Aviretta. The project was executed according to the original schedule, despite Covid-19 restrictions. The paper machine (PM4) produces fluting from 60 to 130 g/m<sup>2</sup>.

Toscotec supplied nine TT SteelDryers of over 7 m face width equipped with

insulation system. One TT SteelDryer also features a ceramic/teflon cover to guarantee high cleanliness following the size press. The scope included condensate spoiler bars, steam joints, bearings and housings, and spares. Toscotec provided Aviretta with a complete set of services, including engineering, disassembly, erection, commissioning, and start-up assistance.





**Thomas Reibelt, Project Manager for Aviretta GmbH,** says, "The cooperation with Toscotec was very good right from the beginning. We are happy to have worked with a supplier who has such a significant experience with rebuilds. The new TT SteelDryers have been performing very well since start-up, with good results in drying capacity and energy efficiency."

**Stefano Baldi, Toscotec's Project Manager,** says, "We implemented this project during the Covid-19 restrictions. We couldn't travel to the mill to take the necessary field data for our engineering

design, like we normally do at the beginning of a new project. With full support from Aviretta, we never stopped progressing with our work and managed to complete the project according to the original schedule."

# Toscotec to supply an AHEAD 2.2S tissue line to Europap Tezol Kağıt in Turkey

Europap Tezol Kağıt will boost capacity with a Toscotec-supplied AHEAD 2.2S tissue machine at its integrated production base in Mersin, Turkey. This is a repeat order for Toscotec who already supplied a TT SYD steel Yankee dryer installed on their PM1 in 2012. The new line is scheduled for start-up in mid-2022.

The AHEAD 2.2S machine has a sheet trim width of 2,920 mm, a maximum operating speed of 2,100 mpm, and an annual production capacity of over 40,000 tons. It is equipped with TT NextPress with upgraded design, third-generation TT SYD, TT Reel-BulkyReel for optimal preservation of bulk and softness, and high efficiency

TT Hood with automatic balancing system.

The supply features the complete stock preparation system and Toscotec's patented TT SAF® (Short Approach Flow) equipped with a double dilution system to ensure electrical consumption reduction. The scope also includes Toscotec's proprietary DCS system, electrification and controls, as well as dust and mist removal systems. Two OPTIMA slitter rewinders fitted with an automatic shaft puller complete the supply. Toscotec will provide a complete service package with detailed mill engineering, erection supervision, commissioning, training, and start-up assistance.



**Ersin Tezol, CEO of Europap Tezol Kağıt,** says, "Our production capacity expansion required the most advanced technology at a cost-attractive price. Toscotec's technology was the best choice to meet the strict environmental requirements of our company and the high quality standards of our super-prime brands, especially for softness and hand feel."

**Matteo Giorgio Marrano, Toscotec's sales manager,** says, "This AHEAD 2.2S machine will allow Europap Tezol to achieve its target of production increase and prime quality. The configuration with TT NextPress and TT SYD of new generation and high recovery TT Hood aims to provide the highest possible level of energy efficiency on a tissue production line. Toscotec also strengthens its presence in the Turkish market, which is growing into a key market in the EMEA region."



**Toscotec introduces  
TT Defender for  
effective protection  
of steel Yankee dryer**





Toscotec has launched TT Defender, a groundbreaking innovation in the tissue market that consists of a special coating for the internal surface of its TT SYD steel Yankee dryer for protection against corrosive steam. TT Defender has been successfully applied on a TT SYD that is operating at Lucart's Diecimo tissue mill in Italy.

Since steel Yankee dryers have outperformed cast iron Yankees and replaced them as the new technological standard of the tissue industry, more pressure has been put on paper mills to more frequently check steam quality. In order to maintain steam parameters such as pH and conductivity within the correct range, increased monitoring and expertise has become a "best practice". TT Defender is Toscotec's pioneering solution: an extremely uniform layer ensuring excellent resistance to highly corrosive conditions. It prevents the risk of chemical corrosion and related problems including mechanical abrasion, erosion, and straw pipes plugging that can lead to an uneven humidity profile.



By virtue of its extremely low thickness, TT Defender does not affect the high drying efficiency of TT SYD. Instead, it increases its O.E.E. (Overall Equipment Efficiency) by greatly reducing the risk of unplanned maintenance stops due to soda straw plugging or internal corrosion issues and reducing time needed for regular internal inspection. This all leads to a greater plant performance.

**Jacopo Bibbiani, Toscotec R&D mechanical engineer**, says, "We constantly upgrade the design of TT SYD. TT Defender stems from this very logic of continuous improvement: based on the service experience we acquired in more than 20 years on over 200 TT SYD operating around the globe, this innovation is set to make the difference for many paper mills. Customers will benefit from the excellent performance of TT SYD and will be able to enjoy a higher flexibility in controlling the water quality of their steam and condensate system."



# JSC Yarpaper successfully starts up PM1 after major rebuild by Toscotec

Toscotec successfully accomplished an extensive rebuild of Russian containerboard manufacturer JSC Yarpaper's PM1 at their mill in Yaroslavl, near Moscow. PM1 has a wire width of 2,830 mm and produces 100% recycled-based fluting and test liner in the range from 90 to 175 gsm.

The rebuild has optimized the entire paper machine, from the approach flow system to the dryer section, and has achieved the targets of production increase and quality upgrade.

The scope of the rebuild included the approach flow system, with screens, fan pumps, a TT Headbox-H equipped with TT D-Profiler dilution control system, a newly designed Fourdrinier make up, and the optimization of the sheet path in the press section.

Toscotec installed a completely new dryer section, fitted with 35 TT SteelDryers designed for 10 barg operating pressure, structural frame, canvas rolls, doctors, stabilization boxes, stretchers, guiding, tail threading system, oil lubrication unit,

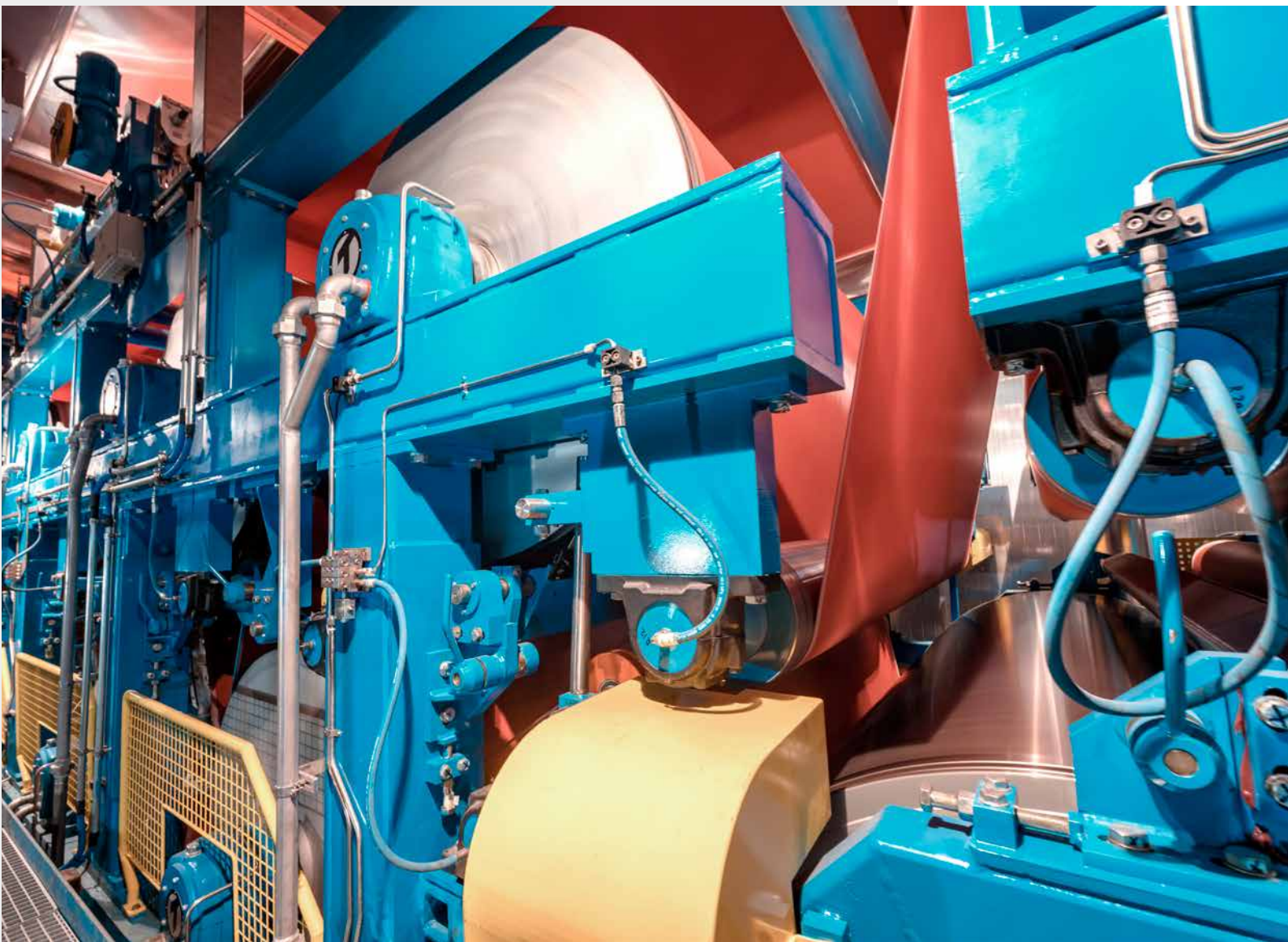

as well as mechanical drives for the entire line.

The project also included a complete service package with engineering, erection supervision, commissioning, start-up assistance, and training.

**Igor Noskov, Project Manager of JSC Yarpaper**, says, "We successfully completed a major rebuilding operation on our paper machine in difficult times during Covid-19. We have expanded our range of high quality containerboard papers to 90-175 gsm and have increased our reel width to 2,500 mm. This will allow us to better serve our Russian customers, and expand to Europe and the Middle East."

**Luca Nesi, Toscotec Start-up Engineer**, comments, "The cooperation with Yarpaper was very good throughout the entire project. They provided the best conditions for Toscotec to work on site during the pandemic. We could thoroughly prepare the machine, so that at start-up we got paper on the pope reel shortly after sending stock to the new TT Headbox. It is a great satisfaction to witness the successful completion of such an extensive rebuild, where we newly designed or extensively rebuilt most sections of the paper machine to deliver a significant production increase."





# Toscotec to supply two TADVISION<sup>®</sup> machines to Hengan Group in China

Toscotec will supply two TADVISION<sup>®</sup> tissue machines to Hengan International Group at its Shandong and Hunan mills in China. Toscotec's TADVISION<sup>®</sup> line is designed to ensure superior bulk, softness and absorbency. With this order, Hengan breaks through the barrier of conventional and textured tissue in the Chinese market, aiming to manufacture top quality structured tissue with the highest bulk, softness and absorbency properties. The start-up is scheduled for 2022.

The new lines will be the first real TAD (Through Air Drying) machines

manufacturing structured tissue to be installed in China. The Fujian-based Chinese Group is thus set to lead the transformation of the Chinese tissue market towards top quality tissue.

Both TADVISION<sup>®</sup> machines will have a trim width of 3,650 mm and an annual production capacity of over 40,000 tons.

This project strengthens the cooperation between Toscotec and Hengan International Group, who in 2017 successfully fired up two Toscotec-supplied MODULO-PLUS ES tissue lines at its Changji mill in Xinjiang province.





**Hui Lin Chit, CEO of Hengan Group,** says, "Hengan always pursues innovation and top quality products; as a result, it leads the development of the Chinese tissue and hygiene market. After scrupulous evaluation, we selected Toscotec as the partner to support us to achieve our new target."

**Alessandro Mennucci, CEO of Toscotec,** says, "We are very pleased to partner with Hengan on this strategic project. Toscotec's new TADVISION® machine represents the cutting-edge technology they need to bring about a historical change in the Chinese market."

**Michael Zhao, General Manager of Toscotec Paper Machine (Shanghai) Co., Ltd.,** says, "The Chinese tissue market has been tackling the issue of overcapacity in recent years. Our latest TADVISION® machine will enable Hengan to manufacture a completely differentiated and top quality product. This will allow them to both set apart from the fierce red ocean competition of conventional tissue, and to open up and lead an entirely new, blue ocean structured tissue market."

# MEPCO signs with Toscotec Toscotec to supply tissue machine for MEPCO's new tissue mill

Today MEPCO and Toscotec signed a turnkey supply contract for a high efficiency AHEAD 2.2L tissue machine. Toscotec is one of the world's leading manufacturers, specialized in turnkey projects, complete lines, rebuilds and single equipment for the tissue and paper & board industries.

MEPCO's tissue machine will have a production capacity of over 60,000 tons per annum of tissue jumbo rolls, covering a wide range of basis weights. The AHEAD 2.2L machine features a TT NextPress shoe press with an upgraded design, a third-generation TT SYD Steel Yankee Dryer, and top efficiency TT Hood-Multigen with cogeneration integrated air system.

Toscotec will supply the new line on a turnkey basis, including two OPTIMA 2600L slitter rewinders designed to ensure superior bulk and softness preservation. The manufacture of the machinery will take place in Lucca, Italy starting from the first quarter of 2021, and is expected to complete within 12 months. The test-run of the new line is scheduled in the first quarter of 2023, followed by commercial production.

MEPCO announced entering the tissue jumbo roll manufacturing in December 2020. A lucrative opportunity to fill a significant import gap in the local market, which enjoys population growth and high GDP per capita, but limited local supply.



**Sami Safran, CEO of MEPCO,** commented: "This is the first milestone in our new tissue project. We are progressing according to the planned timeline. Signing the machinery supply contract with Toscotec puts us at comfort about the product quality and efficiency, which are essential to position our products perfectly in the market. We think big, and have an ambitious vision to realize. MEPCO enjoys an international reputation for being among the lowest cost producers of containerboard. With the expertise of its management team, it has a concise plan to extend its cost efficiency techniques to the tissue manufacturing business. With Toscotec as our partner of choice, I am looking

forward to realizing the maximum potential of this milestone project".

**Alessandro Mennucci, CEO of Toscotec,** said: "We are delighted to receive a new order for a state-of-the-art turnkey operation from such an important group as MEPCO. It is also a milestone for Toscotec, who is entering the Middle East market with an advanced high-speed tissue line designed to manufacture premium quality tissue, with a high level of energy efficiency ensured by the integration with the cogeneration system".

# — Toscotec launches new YES-CONNECT-VISION AR system for effective remote service



Toscotec upgraded its YES-CONNECT-VISION AR (Augmented Reality) system to provide faster and more effective remote services. After launching the first version in 2018, Toscotec perfected the system based on user feedback and practice in the field. With this improved tool, mill operators wearing an ergonomic helmet fitted with a high definition camera send out high-resolution images and audio in real time, becoming the eyes and the ears of Toscotec's service team inside the mill.

Toscotec's experts can actively interact with these inputs in real time by highlighting components in the operator's field of view, sending relevant documentation to their helmet's visor and guiding them on adjusting the machine. Toscotec's service team can acquire all the information they need to provide solutions, get around lack of technical know-how, or language-related issues in communication.

YES-CONNECT-VISION is designed to ensure maximum safety to the operator who is wearing the helmet with dust-tight and watertight hardware. With an easily adjustable binocular visor, a wide angle camera that offers a 150-degree visual field, a selective microphone and noise-cancelling headset, technicians can safely move around in the mill with large visibility of surroundings, and operate hands-free, while receiving clear audio signals even in highly noisy areas.

YES-CONNECT-VISION digital solution increases service efficiency, thereby reducing downtime and boosting production efficiency. When travel options are limited or if it's desired to retain the option of on-demand remote service, Toscotec offers an effective tool that reduces downtime, costs and carbon emissions.

**Girolamo Panepinto, Toscotec Start-up & Service Software Engineer**, says: "YES-CONNECT-VISION is perfectly suited for trouble-shooting service, on-remote factory acceptance tests, and commissioning tests. Customers can also use it for one on one training at the customer site, or group training from the Toscotec factory floor. For instance, a Toscotec engineer could demonstrate a maintenance task with up to 11 remote connected viewers. With price-competitive service subscriptions, paper mills can get 24/7, worry-free service. We are simply a phone call away from the solution to their technical problem."

# — Lucart validates Toscotec's TT Defender ability to increase Yankee efficiency

Toscotec has recently introduced TT Defender, a leading-edge patented innovation that provides Yankee dryers with an effective internal protection coating against corrosive steam. Toscotec has successfully tested TT Defender at Lucart Group's Diecimo tissue mill in Italy on a TT SYD that came online in February 2020.

**Danilo Calamari, Lucart's Paper Mill Senior Engineer & Cogeneration Plants Manager**, is the technical expert who closely followed the project in Lucart. In this interview, he shares Lucart's experience with TT Defender and his professional views on the results they achieved so far.

**The TT SYD installed on your PM5 in Diecimo is fitted with TT Defender. During the regular checks you performed 6 months after start-up, you personally**

**entered inside the Yankee. Which conditions did you find?**

D.C.: I was pleasantly surprised at how good the Yankee looked inside. During our regular Yankee checks, we often find some magnetite deposits and soda straw blockage. Instead, the TT SYD on PM5 appeared as if it were new, or even better: the entire internal surface and all the straw pipes were perfectly clean. Evidently, during its six months of operation, no magnetite deposits had formed inside the Yankee. This result validated our decision to participate in this project. To be honest, at the beginning when Toscotec suggested they test this new technology on our TT SYD, we were not entirely convinced. Finally, we decided to get on board, because we have had a very good cooperation with them for many years, and we trust their professionalism and reliability as a supplier.



**Mill technicians know very well that in the ordinary operation of the steam and condensate system, it is quite common to go through transitory phases or issues that cause some of the chemical and physical values under control to fall short of the requirements for the proper functioning of the plant. Does TT Defender represent an additional security in this regard? Do you think that it allows your Yankee to have a greater tolerance to these kind of normal variations?**

D.C.: Yes, we do. TT Defender allows us to overcome some possibly critical issues in the chemical treatment of the steam and condensate system of PM5 without consequences. We can now successfully manage these phases that are completely normal throughout the year.

**Before the TT SYD with TT Defender, Toscotec had installed another TT SYD on your PM6, which is right next to PM5 and shares the same steam and condensate system. In terms of drying performances, did you find that the drying capacity of the steel Yankee with TT Defender was any different from the other?**

D.C.: Apart from TT Defender, the two TT SYDs installed on PM5 and PM6 have the same characteristics, so we could easily compare their performances under various operating conditions. We did not find any limitation in the drying capacity of the TT SYD with TT Defender. Before the application, one might wonder

if TT Defender could hinder the heat exchange between the Yankee's internal and external surface on which its drying capacity is based upon. The actual result is that TT Defender does not affect the Yankee's thermal efficiency in any way. In one year of operations, we found that the two TT SYDs on PM5 and PM6 perform equally well.

**Do you think that TT Defender allows you to eliminate the risk of longer maintenance stops due to the obstruction of soda straws?**

D.C.: At Lucart, we perform one regular internal Yankee inspection per year. We will check PM5's TT SYD this summer, but what we can say now is that we are not experiencing any issues with tissue quality that could point to soda straw blockage. The paper we are producing on PM5 is high quality and has a very uniform cross-direction moisture profile. This suggests that when we will open up the Yankee later this year, we will most likely do just a quick check, without allocating extra personnel and extend the downtime in order to clean or replace soda straws. With TT Defender, we expect to find a Yankee that is always clean, and allows us to realize the best production efficiency in terms of both quality and quantity.





# SPEED? — — AHEAD.

Speed is not an option and when joined by leading-edge technology, evolved engineering and the highest levels of performance, it becomes a must.

Toscotec allows you to reach this goal with its **AHEAD Line**: the high-speed tissue machine range capable of attaining 2,200 mpm and producing high-quality tissue from virgin and recycled fiber with proven energy savings, maximum efficiency and reliability.

**The performances your business was just waiting for.**

YOUR NEEDS — OUR SOLUTIONS

# Toscotec finalizes a drying section rebuild at Cartiera San Giorgio, Italy

Cartiera San Giorgio successfully started up its PM1 after the complete rebuild of its dryer section by Toscotec. PM1 has a trim width of 2,500 mm, and produces wet creped tissue in the basis weight range from 30 to 50 gsm, using virgin cellulose and recycled paper.

Following the installation of a TT SYD Steel Yankee Dryer that replaced PM1's existing cast-iron Yankee in 2012, Toscotec has now completed the full upgrade of the drying section of this paper machine by rebuilding the post-dryer section. The rebuild supply included eight TT SteelDryers designed for an operating steam pressure of 10 barg, and the tail threading system installed between the TT SYD and the post-dryer section. The project also includes the engineering design, on site erection, commissioning and start-up assistance.



**Alessandro Ardinghi, owner of Cartiera San Giorgio**, comments: "The targets of this rebuild have been fully accomplished. We optimized PM1's production and significantly improved the moisture profile on the edges. We have known Toscotec for many years, and we are happy with how they managed the project and delivered on the results we expected."

**Gian Luca Fornesi, Head of Sales Application at Toscotec**, says, "With this project, Toscotec confirmed its ability to address and resolve specific production problems. For Cartiera San Giorgio, we carried out a survey and developed a custom-made design for their TT SteelDryers, in order to meet their needs and eliminate their production bottlenecks."



# Toscotec-supplied turnkey tissue line achieves top speed at Paloma

The AHEAD 2.2L tissue machine supplied by Toscotec to the Slovenian tissue producer Paloma has achieved its top speed and performance at Sladki Vrh mill. Paloma d.d., part of the Slovak Hygienic Paper (SHP) Group, purchased its new line from Toscotec on a turnkey basis and has confirmed that the machine has fulfilled all the conditions for take over acceptance.

The new line completely replaced the previous PM6, calling for a customised design of the process and the layout that respected the constraints of the available space and at the same time guaranteed the highest production efficiency.

The AHEAD 2.2L tissue machine has a 5,500 mm sheet trim width, 2,000 m/min operating speed and a daily production of 220 tons. Designed to guarantee the lowest possible energy consumption, it features Toscotec's shoe press TT NextPress, TT SYD, gas-fired TT Hood with multiple stages of energy recovery.

The turnkey supply included the stock preparation equipment and accessories, Toscotec's patented TT SAF Short Approach Flow, the complete electrification system, the dust and mist removal systems, and a shaft puller integrated with the pope reel. The new line is completed by Toscotec's









newly designed OPTIMA 2600 slitter rewinder, equipped with four unwind stands, an automatic NIP control system and integrated shaft puller.

The service package included the full range of operations from dismantling to erection, supervision, training, commissioning and start-up.

**Stevan Lomic, Technical Director of the SHP Group**, says: "We achieved the target of equipping Paloma with advanced technology to produce at full capacity. We are manufacturing premium quality tissue, and are very happy with product quality. Toscotec has shown extreme flexibility in these challenging times and has completed the project with great professionalism. "

**Stefano Raffaelli, Project Manager at Toscotec**, says: "Paloma's project started off as a particularly interesting and challenging one, where we tailored our solutions to the existing plant and managed the necessary changes during the course of the project focusing on our targets. The Covid-19 outbreak posed an even bigger challenge, but we tapped into our great flexibility and ability to take fast decisions when faced with unexpected events in order to respect the timeline. With great cooperation from Paloma's team we accomplished our common goal."

# — Toscotec accomplishes a dryer section rebuild at Cartiera di Ferrara, Italy







After a complete dryer section rebuild supplied by Toscotec, Cartiera di Ferrara fired up PM1 at its mill in Ferrara, Italy. Toscotec modified the entire dryer section, without changing its overall length and therefore leaving the positions of the press and the pope reel unchanged. This allowed for a very short shutdown time because civil works were not necessary to achieve the planned production increase. The paper machine achieved stable production immediately after start-up.

Toscotec refurbished the first dryer section with the supply of new felt rolls, guide and stretchers, and a modification of the frame structure. The second section was completely rebuilt with 16 new TT SteelDryers of 1,829 mm diameter designed for an operating steam pressure of 10 barg. Toscotec supplied new silent drives for the transmission of the entire dryer section that significantly improved PM1's conditions for operation and maintenance. The scope comprised a full set of services, including mechanical erection, supervision, commissioning, and start-up assistance.

**Alessandro Castelletti, Mill Manager of Cartiera di Ferrara**, says: "Toscotec executed the rebuild with competence and according to the agreed time plan. We boosted PM1's operating speed because of the increased drying capacity of our new dryer section. We will progressively continue to raise the speed as we still have margin. The production is stable, and we are happy with the results we achieved so far."

**Stefano Baldi, Toscotec Project Manager**, says: "We lived up to the double challenge of a tight project schedule that began right before Italy enforced nationwide Covid-19 restrictions. We managed to complete on time the pre-assembly phases during lockdown, and then finalized the installation according to schedule. We are happy to see that Cartiera di Ferrara is already increasing their production capacity as a result of this rebuild."

# — Toscotec's new tissue line starts up at Thai C.A.S. Paper Mill



C.A.S. Paper Mill started up an AHEAD 1.5S tissue machine supplied by Toscotec at its Sing Buri mill in Thailand.

The new AHEAD 1.5S machine has a trim width of 2,850 mm, an operating speed of 1,850 m/min, and produces more than 30,000 tpy of premium quality tissue. The machine configuration is designed to guarantee top energy efficiency with TT NextPress shoe press design, TT SYD Steel Yankee Dryer, and steam-heated TT Hood-Hybrid.

The supply included the stock preparation equipment and accessories, the patented TT SAF (Short Approach Flow) system, the fiber recovery system, dust and mist removal systems, and a complete slitter rewinder line, with dedicated dust removal system. Toscotec also provided a comprehensive service package, including the tissue machine's erection, erection supervision, commissioning, training and start-up assistance, as well as YES-CONNECT-VISION Augmented Reality solution for remote service.

**Torpong Thongcharoen, Managing Director of C.A.S. Paper Mill**, said: "With this new line C.A.S. Group enters the tissue market. We are already producing high quality tissue, and we expect to kick off distribution very quickly. Throughout the entire project, including the hardest times during the pandemic, we always had a very good cooperation with Toscotec, who proved to be the experienced and skilled supplier we expected, managing the project with great flexibility and supporting us all the way to our target."

**Marco Dalle Piagge, Toscotec Sales Director**, comments: "This start-up is a reward to us all for the hard work we put into this project in order to successfully complete it during Covid-19. This AHEAD line is designed to deliver top energy efficiency that results in low energy consumptions and low operating costs. C.A.S. Paper Mill is now fully equipped to enter the tissue market from an advantage position."

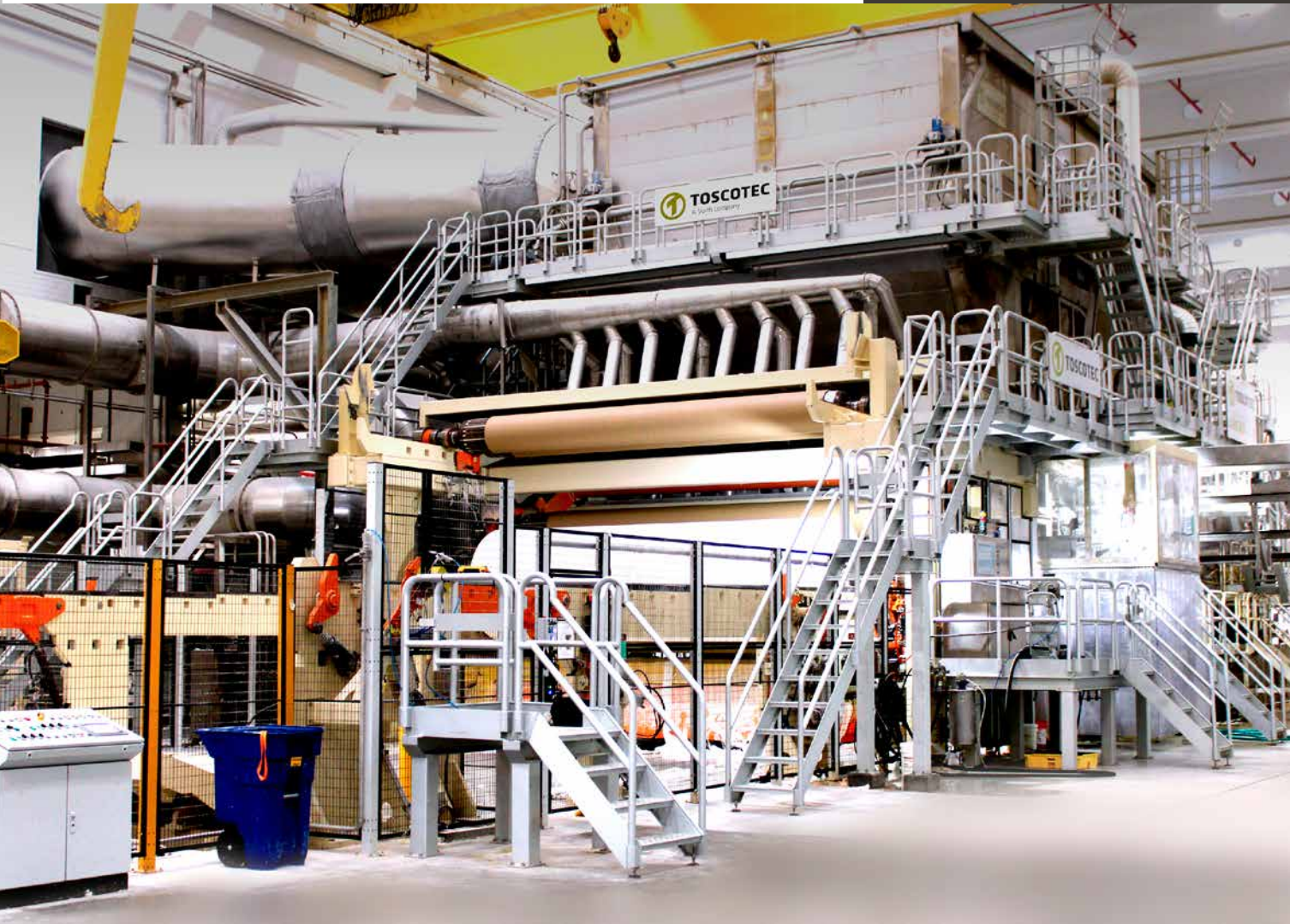

# — Sofidel attains high efficiency and premium quality on Toscotec's lines

In 2020, Sofidel added 120,000 tons a year to its production capacity in the USA with two Toscotec AHEAD 2.0L paper machines in 5,500 millimetre format with an operating speed of 2,000 metres a minute. Toscotec has delivered a turnkey product for the tissue-making area of Sofidel America's integrated paper mill in Inola, Oklahoma.

Since the launch of two new lines, Sofidel has been manufacturing premium quality tissue paper, in compliance with its rigorous quality standards, and has maintained a high level of operating efficiency, fully benefiting from the energy and environmental efficiency of Toscotec's AHEAD lines, which feature the TT SYD Steel Yankee Dryer and high energy recovery TT Hoods.

In this interview, Simone Capuano, the Executive VP, Operations & Supply Chain,

of Sofidel America Corp. discloses the strategy underpinning this investment and tells us what Sofidel has achieved so far at its Inola production base.

## **Sofidel America's new integrated production base in Inola: what were the reasons for this expansion and for choosing Toscotec's technology?**

The construction of an integrated plant in Inola (Oklahoma) is an important part of the growth strategy that Sofidel has implemented in the USA since its arrival in the country in 2012. After Circleville (Ohio), this is the second greenfield investment of our Group in the USA, aimed at increasing our production capacity and our geographical coverage, which means having plants close to our customers - in this case, specifically, we are in the southern region - in order to improve our service and contain logistical costs. In this context, Toscotec was the

right choice, because its technology is efficient both from the energy and environmental points of view, and because of the experience and flexibility they have gained in our sector.

**Toscotec was your turnkey supplier for paper mill production on the Inola project. Was it helpful for you to have a single company as your reference point for this part of the supply?**

Building a new paper mill from scratch is never an easy task, both for technical and organizational reasons. In Oklahoma, like everywhere else in the USA, we have been able to count on excellent collaboration from local institutions and partners. We certainly found it very helpful to have a single supplier as our contact for the paper mill production part, especially since part of the project was carried out in the first and most complicated stage of the COVID-19 emergency, with all the problems that implied.

**Are you satisfied with Toscotec's management at this time of global emergency?**

Even though we had to face unpredictable and complicated situations, Toscotec's flexibility, contribution and spirit of collaboration have never been lacking. We appreciated their dedication and problem-solving skills.

**Once Toscotec's machines came on line, did you see an increase in the OEE (Overall Equipment Effectiveness) compared to processing reels from other production sites, as you were doing before? Has converting efficiency improved? If yes, why?**

Having an integrated plant has already improved production efficiency. Furthermore, the AHEAD 2.0L machines used on our lines represent a tried and tested technology that did not require any fine-tuning. As we expected, they were immediately found to be in line with the needs of our customers. The fact that we could count on reels with a larger diameter and constant quality has definitely allowed us to increase the efficiency of our converting lines.

**What grades are you currently manufacturing on PM1 and PM2? What is your assessment of product quality?**

The quality standard is high and meets our customers' requirements and, at the same time, it allows us to achieve excellent performances at the plant in terms of energy efficiency and optimization of raw material use. This is in line with Sofidel's commitment to reconcile the market and consumption needs with those of sustainability. On the two machines, we are producing various grades both for toilet tissues, with particular attention to Super Soft papers, and kitchen towels.

**Are you satisfied with the specific consumption of chemical products per ton of paper produced that is being recorded by the two machines?**

Yes, we are also recording significant improvements in this area, although the optimizing of the entire system must continue.

**Overall, how would you describe the cooperation with Toscotec?**

A positive cooperation built on hard work and mutual commitment to continuous improvement.

# Toscotec to supply a wet end rebuild to Dunn Paper in Michigan



Dunn Paper selected Toscotec for the rebuild of the wet section of PM2 at its Menominee paper mill in Michigan, USA. The paper machine produces specialty papers including MG grades and flexible packaging products.

In 2017, Toscotec had installed a custom-made TT Headbox at Dunn Paper's St. Catharines paper mill in Canada. Based on the successful experience of this rebuild, Dunn Paper Menominee asked Toscotec to create a preliminary

engineering solution that met PM2's production and quality targets. Finally, Dunn Paper awarded the rebuild order to Toscotec, valuing the importance of a fully-customized technical offer based on the analysis of the machine's operating data. Toscotec will supply the approach flow system, and a hydraulic TT Headbox-SL fitted with dilution control. The service package includes erection supervision, commissioning, and start-up assistance.





**Steve Michalko, Dunn Paper Manufacturing Director**, says: "In recent years Dunn Paper has been making significant investments into our mills and processes in order to better ourselves and meet the demands of the ever changing market and standards of our growing customer base. By upgrading to a Toscotec dilution profiled headbox in addition to their screening and water system improvements, we will improve the uniformity and formation of our base sheet, increasing our capability to meet current and future customer requirements. A big thanks to Toscotec for helping with this mill improvement."



**Fabrizio Charrier, Toscotec Sales Manager**, says, "Having the chance to support Dunn Paper Menominee on this rebuild makes me very proud. Toscotec's TT Headbox-SL has a consolidated design that has proved successful on numerous references over the years. This important project confirms that Toscotec can rebuild all sections of the paper machine, and this will open up new opportunities for Toscotec in North America to supply key paper machine components, project studies and tailor-made solutions."

# Toscotec steps up Yankee Hood efficiency with TT Drying Equilibrium

Toscotec boosts the drying efficiency of its tissue lines with TT Drying Equilibrium, a simple and reliable system that ensures an optimal and automatic regulation of the air balance in the Yankee hoods and air system. The system was originally designed by Voith and transferred to Toscotec for further development in the synergy-creating cooperation established with the acquisition. TT Drying Equilibrium measures several attributes of the air going in and out of the hoods, and automatically adjusts the system to guarantee the highest productivity and energy efficiency.

**Stefano Pecchia, Energy Technology Director at Toscotec**, says: "In a properly balanced hood system, the masses of gases - vapour and dry air - that are fed into the system are equal to those that go out through the chimney as exhaust air. This balance is crucial to avoid fresh

air getting in and hot air going out during manufacturing; in this way, you can achieve maximum drying efficiency. We recommend the automatic balancing system especially on tissue machines that frequently change basis weight during the production cycle. It would be more complicated for operators to balance the system manually at every change; TT Drying Equilibrium makes these adjustments automatically, in a much faster and more effective way."

The control and regulation logics are managed by a dedicated PLC (Programmable Logic Controller) that communicates with the DCS (Distributed Control System) of the tissue machine. The mill can easily access the data collected, stored and organized by the PLC on local monitors, tablets, or smartphones, through a remote connection.

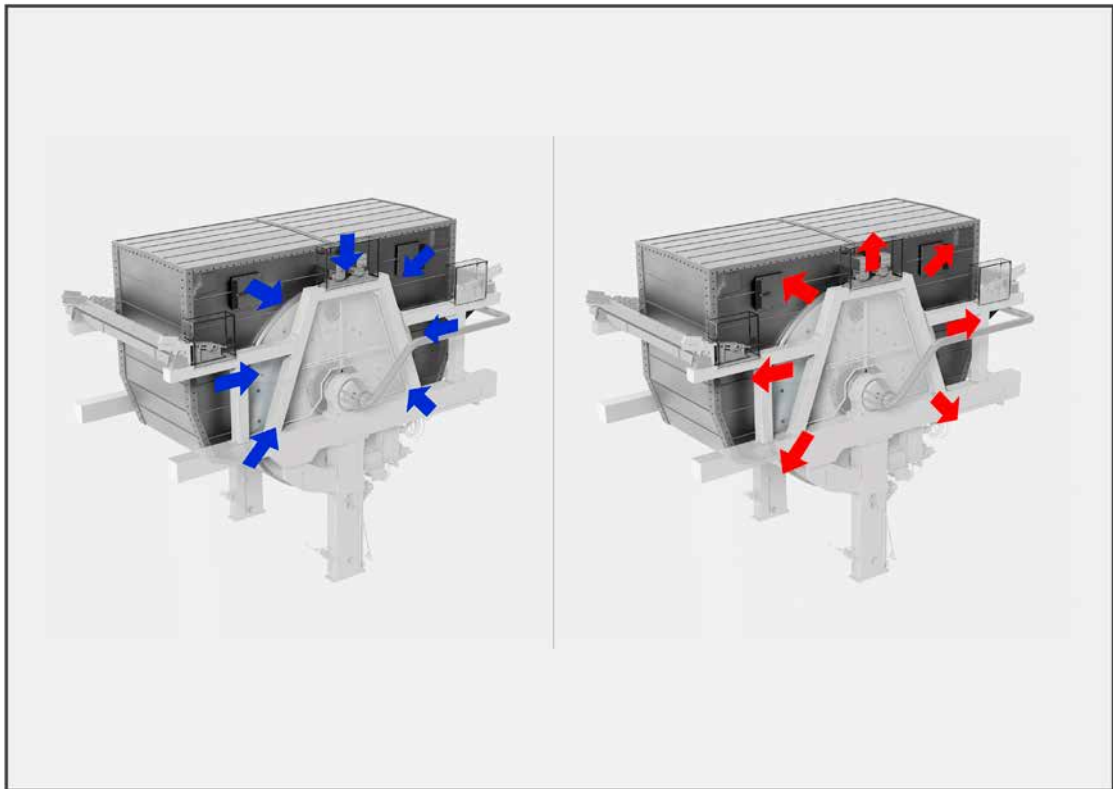

### Ensure product quality

A lack of balance in the hoods can be triggered both by over-pressure that causes hot air to go out, and by under-pressure that causes cold air to be pulled into system through the gap between the Yankee and the hoods. These imbalances will reduce energy efficiency, give rise to paper quality issues, cause environment-related issues, and potentially be unsafe to personnel. In fact, in the event of air suction, cold air on the paper can lead to

its detachment from the Yankee surface and to an uneven moisture profile. In case of over-pressure, hot air can cause overheating of the surrounding area with increased fire risks, discomfort or danger for operators, possible damage to adjacent equipment, and deterioration of the environmental conditions of the machine hall. By ensuring hood balance, TT Drying Equilibrium contributes to effectively avoid these issues and deliver the best possible product quality.

**An effective twofold balance control**

TT Drying Equilibrium consists of a set of various transmitters of physical data, including speed, flow rate, temperature, humidity, and pressure, and of a data acquisition and processing system.

The calculation algorithms produce the mass flow rates inside all the air ducts leading into and out of the Yankee hoods, including outgoing air, make-up air, and combusive air both on wet-end and dry-end.

The combustion air is regulated by the burner control system, while the flow of exhaust air can be regulated by the moisture control loop. TT Drying Equilibrium controls the dampers that allow for make-up air to enter the system, thereby maintaining a condition of balance over time.

In addition to controlling the air mass flows, the system also checks the actual balance using temperature sensors installed just outside the Yankee-Hoods gap and of pressure transmitters inside the hoods. As a result, TT Drying

Equilibrium delivers an effective twofold balance control in real time, based on the calculated balance of the masses, and on the confirmation that hot air is not escaping or cool air is not being pulled in around Yankee and Hoods.

**A key tool to monitor machine efficiency & optimize production and maintenance**

TT Drying Equilibrium also enables real time monitoring of the energy performance of the tissue machine. It processes production data acquired from the DCS and produces precise figures or trends relating to the tissue machine's energy consumptions, including steam, gas, and electrical power consumption.

It also acquires key data of the air system's heat recovery units, including inlet and outlet temperatures and flow rates, to monitor their performance, and plan maintenance activities. This allows the mill to check production efficiency by product over time, and to perform preventive maintenance.

# iT's Tissue 2022. The convergence of tissue excellence.

**6-10 JUNE**

LUCCA • BOLOGNA - REGGIO EMILIA • LECCO



[itstissue.com](http://itstissue.com)

**iT's** *tissue!*

THE CONVERGENCE  
OF TISSUE  
EXCELLENCE

# Toscotec introduces new shoe press generation design for tissue

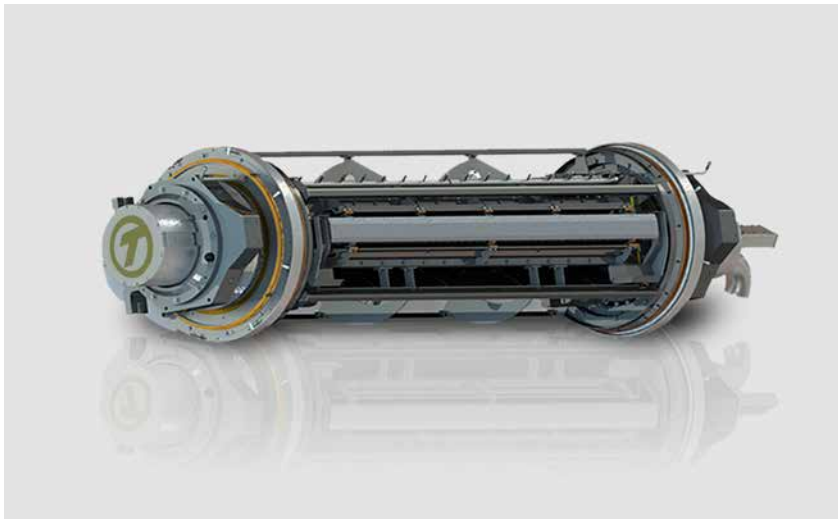

**Toscotec has launched the new generation design of its shoe press TT NextPress, featuring superior drying performances and energy savings, resulting from R&D activities in cooperation with Voith.** TT NextPress delivers a stable after-press dryness

rate of more than 47% on a tissue line operating above 2,000 mpm speed. This dryness level ensures a substantial reduction of energy consumption, as the Yankee and the hoods use significantly less thermal energy to complete the paper drying process.

### **Superior Dewatering delivers higher Dryness**

A new shoe shape has been introduced to enhance the nip width and increase the peak pressure at the nip outlet, reshaping the outward pressure into a steeper curve. This eliminates the risk of paper re-wetting at the exit of the nip, and increases sheet dryness, without affecting the belt's life.

### **Continuous Nip Control for maximum Reliability**

Machine operators can now visualize on the DCS (Distributed Control System) the actual nip pressure of TT NextPress in real time. The operator can regulate the nip pressure at which the TT NextPress is loaded onto the Yankee resulting from both a theoretical and empirical system, as the nip pressure is calculated based on the shoe press loading system and also measured by the load cells installed on the press mechanical stop.

### **Higher Precision: the perfect fit for Rebuilds**

In rebuilds, the installation of a shoe press on an old-style cast iron Yankee can compromise the lifetime of both the felt and the belt. Toscotec has designed a dedicated solution on the TT NextPress consisting of multiple independent pressure zones, up to 14 in total, of which 12 are located on the edges. This design ensures a perfect fit between the shoe and the Yankee deformation, and maximizes the clothing lifetime.

### **Improved Safety and Yankee Protection**

TT NextPress nip pressure lines are fitted with a pressure accumulator pre-charged with nitrogen, which is installed inside the belt as close as possible to the loading pistons. The accumulators absorb instantaneous overloads or pressure increases on the line due to the presence of external elements or paper wads in the nip area. This eliminates the risk of any possible damage to the Yankee dryer.

The new TT NextPress builds on the features of its previous version which have been widely appreciated by tissue producers around the globe. These include:

- the hydraulic loading system, which ensures top pressure uniformity and reliability
- the extreme flexibility offered by the shoe tilting regulation during operations
- the maximization of the belt lifetime both through the continuous digital monitoring of the heads position with regular lateral movements of the belt, and through the sleeve tensioning device actuated by hydraulic cylinders, which delivers a constant and adjustable stretching force.

Toscotec, together with Voith, has sold more than 60 shoe presses for tissue machines all over the world.

# Toscotec to supply an AHEAD 2.2S tissue line to Saudi Paper Group

Toscotec will supply an AHEAD 2.2S tissue machine to Saudi Paper Group (SPG) at its Dammam paper mill in Saudi Arabia. The new PM2 will produce premium quality tissue from virgin pulp. The start-up is scheduled for the fourth quarter of 2022.

The AHEAD 2.2S line has a sheet trim width of 2,850 mm, a maximum operating speed of 2,100 mpm, and an annual production capacity of over 30,000 tons. Designed for top performance and optimal energy efficiency, the tissue machine is equipped with TT NextPress new shoe press

design, a third-generation design TT SYD Steel Yankee Dryer with patented deckle head insulation, and high efficiency TT Hood.

The supply includes the stock preparation system and Toscotec's patented TT SAF® (Short Approach Flow) featuring a double dilution system that reduces electrical consumption to a minimum. The scope also includes Toscotec's proprietary DCS system, and one OPTIMA slitter rewinder. Toscotec will provide a complete service package with detailed mill engineering, erection supervision, commissioning, training, and start-up assistance.





**Yousseri Abdel Hamid Abdel Aziz El Bishry, CEO of Saudi Paper Group,** says, "Toscotec's AHEAD tissue machine will increase SPG's production capacity of tissue paper from 100,000 to 130,000 tons per year. It is a strategic expansion for our group, and we believe in the importance of equipping ourselves with leading-edge technology that will allow us to achieve our production targets with optimal performance and energy efficiency, delivering the highest quality to our customers."

**Alessandro Mennucci, CEO of Toscotec,** says, "We are very pleased to begin a new partnership with Saudi Paper Group. This project further strengthens Toscotec's position in the Middle East region. SPG will attain its objectives and fully benefit from the optimal performances, high reliability and energy efficiency of this AHEAD tissue line."



# Toscotec to supply a TT SYD Steel Yankee Dryer to Mirae Paper

Toscotec will supply a third-generation design TT SYD Steel Yankee Dryer to the South Korean tissue manufacturer Mirae Paper at their Jeonju paper mill. This is a repeat order from Mirae Paper who installed their first TT SYD on PM3 in 2013. The new steel Yankee will replace PM2's existing cast-iron cylinder and it is scheduled for start-up in the second half of 2022.

The third-generation design of TT SYD Steel Yankee Dryer benefits from an ideal ratio of the weight, width and pitch of the internal ribs and the optimization of the shell thickness. The scope of supply includes the condensate removal system and Toscotec's patented heads insulation for maximum thermal energy efficiency. The associated services include the complete project management, erection supervision, operation and maintenance training, commissioning and start-up assistance.

The TT SYD will be manufactured at Toscotec's fully integrated TT SYD Technology Center in Massa (Italy), situated just 3 kilometers away from seaport to ensure fast and safe shipping operations.

Toscotec is continuously upgrading the design of TT SYD, benefiting from the vast experience of over 200 TT SYD running across 5 continents worldwide under the most diverse operational and environmental conditions. This year, Toscotec has launched TT Defender®, a breakthrough patented innovation that equips TT SYD with an internal protection coating against corrosive steam.



**Yeong Rok Lee, Mirae Paper's Production Manager**, says, "The steel Yankee on PM3 has been operating efficiently for over 8 years, allowing us to reduce our thermal energy consumption by a significant amount. We expect the new Yankee on PM2 to be as reliable and to deliver even higher performances, considered the design upgrades that Toscotec has implemented on their TT SYD since our first installation. We consider the Yankee dryer to be the core component of our tissue machine's drying capacity. We chose the best technology available in the market, with all the technical support we need from an expert supplier."

**Gabriele Martinelli, Toscotec's Sales Manager**, says, "It is very rewarding that Mirae Paper has chosen Toscotec for the second time on their Yankee replacement. Toscotec strengthens its position in South Korea, where it is the only supplier of steel Yankee dryers, with 12 TT SYD sold in 9 years, including two installed on Toscotec's AHEAD tissue lines."

This order was obtained with the support of CleanTech Corporation, Yongin, South Korea.

# YOU ————— US

You imagine your business idea, we make it happen. We design and supply turnkey plants, machines, systems and components for the production of tissue and paper and board. We link your ambitions to our experience and transform your ideas into the best customized solution for you. Welcome.



# — Toscotec to supply an AHEAD 2.2L tissue line to GrandBay Papelera Internacional



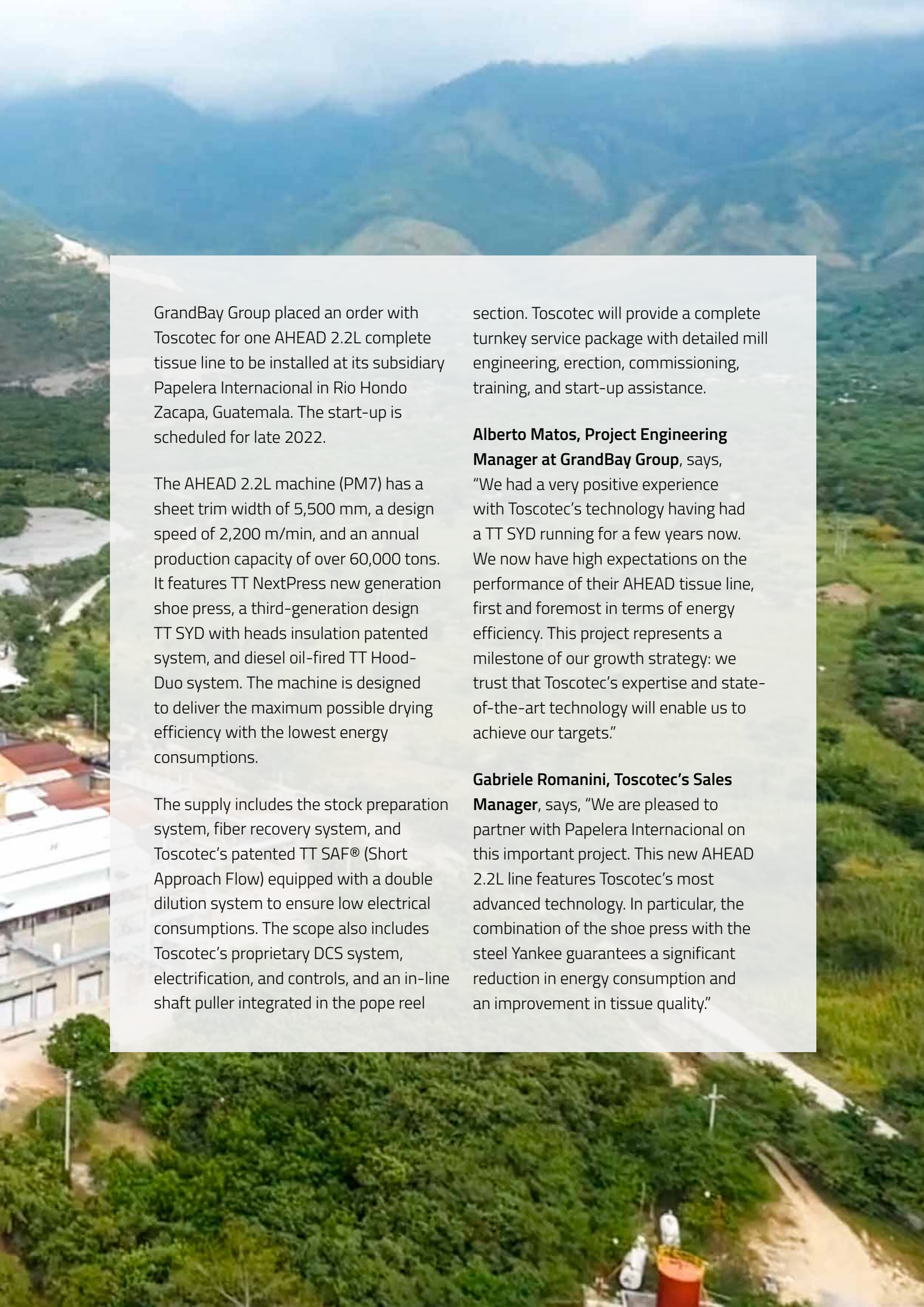

GrandBay Group placed an order with Toscotec for one AHEAD 2.2L complete tissue line to be installed at its subsidiary Papelera Internacional in Rio Hondo Zacapa, Guatemala. The start-up is scheduled for late 2022.

The AHEAD 2.2L machine (PM7) has a sheet trim width of 5,500 mm, a design speed of 2,200 m/min, and an annual production capacity of over 60,000 tons. It features TT NextPress new generation shoe press, a third-generation design TT SYD with heads insulation patented system, and diesel oil-fired TT Hood-Duo system. The machine is designed to deliver the maximum possible drying efficiency with the lowest energy consumptions.

The supply includes the stock preparation system, fiber recovery system, and Toscotec's patented TT SAF® (Short Approach Flow) equipped with a double dilution system to ensure low electrical consumptions. The scope also includes Toscotec's proprietary DCS system, electrification, and controls, and an in-line shaft puller integrated in the pope reel

section. Toscotec will provide a complete turnkey service package with detailed mill engineering, erection, commissioning, training, and start-up assistance.

**Alberto Matos, Project Engineering Manager at GrandBay Group, says,**

"We had a very positive experience with Toscotec's technology having had a TT SYD running for a few years now. We now have high expectations on the performance of their AHEAD tissue line, first and foremost in terms of energy efficiency. This project represents a milestone of our growth strategy: we trust that Toscotec's expertise and state-of-the-art technology will enable us to achieve our targets."

**Gabriele Romanini, Toscotec's Sales Manager, says,**

"We are pleased to partner with Papelera Internacional on this important project. This new AHEAD 2.2L line features Toscotec's most advanced technology. In particular, the combination of the shoe press with the steel Yankee guarantees a significant reduction in energy consumption and an improvement in tissue quality."

# Sappi taps Toscotec for TT SYD Steel Yankee Dryer







Toscotec has received an order from Sappi to supply a TT SYD Steel Yankee Dryer to their mill in Stanger, South Africa. The TT SYD was delivered in record time only 20 weeks after the order. The start-up is planned for the third quarter of 2021.

The cylinder was shipped off from Toscotec's fully integrated and innovative TT SYD Technology Center in Massa (Italy), where Toscotec manufactures all its steel Yankees. The Center is conveniently located three kilometers away from seaport to expedite shipping operations of large diameter Yankees. The scope of supply includes the Yankee steam and condensate system and Toscotec's patented head insulation designed to ensure maximum thermal energy efficiency. Toscotec will provide the complete project management, erection supervision, commissioning, and start-up assistance.

**Nash Ayer, Procurement Manager at Sappi Southern Africa Ltd.**, comments, "We decided on Toscotec because they met our foremost selection criteria of high energy efficiency and reliability. The choice of leading-edge technology such as





TT SYD that will increase the energy efficiency of our tissue line is part of our strong commitment to climate-smart solutions. Given the short timeframe we had on this project, Toscotec gave us their full support by shortening the delivery time."

**Fabio Bargiacchi, Toscotec's Sales**

**Manager**, says, "We are glad to start a new cooperation with Sappi, one of the largest and most innovative pulp and paper producers worldwide. The 20 weeks delivery time obviously posed a big challenge but Toscotec achieved an outstanding result by tapping into the great manufacturing flexibility of its TT SYD Technology Center. With this order, Toscotec further strengthens its position in South Africa, where we have been awarded six new projects in the last 5 years."

With over 200 TT SYD operating in 5 continents across the globe, Toscotec is the undisputed market leader of steel Yankee dryers holding more than 70% market share. Toscotec has manufactured the biggest steel Yankee dryer in the tissue sector, and its TT SYD has been selected for a wide range of applications, including tissue, MG paper, TAD, and tobacco.

Toscotec's continuously growing experience of Yankee dryers operating under the most diverse conditions drives the progress of TT SYD's design and services. In 2021, Toscotec launched TT Defender®, a breakthrough patented innovation that provides Yankees with an internal protection coating against corrosive steam.

# Toscotec to supply a turnkey tissue line to Vajda Papír in Hungary

Toscotec will supply an AHEAD 2.2L tissue line on a turnkey basis to Vajda Papír at its Dunaföldvár mill, near Budapest, Hungary. The start-up is planned for the first half of 2022.

The new AHEAD 2.2L machine features a net sheet width of 5,600 mm, a maximum operating speed of 2,200 mpm, and a production capacity of over 80,000 tons/year. The machine is equipped with the fully hydraulic TT Headbox-MLT, TT NextPress of upgraded design, a third-generation TT SYD, gas fired TT Hood and Air System engineered with several steps of energy recovery.

The turnkey supply includes the complete stock preparation system, Toscotec's patented TT SAF® (Short Approach Flow) with a double dilution system designed to ensure a reduction of electrical consumption. The electrification and controls, dust and mist removal systems, boiler plant, bridge cranes, air compressor station, roll handling and wrapping systems, and hall ventilation with conditioning system complete the production line.





The scope also includes one OPTIMA 2600 slitter rewinder fitted with automatic shaft puller and dedicated dust removal system. Vajda Papír also purchased a comprehensive service package with detailed mill engineering, erection, commissioning, start-up assistance, and training.

**Attila Vajda, owner and managing director of Vajda Papír**, says, "We found in Toscotec the right partner to realize our expansion strategy according to plan. Based on their extensive experience with turnkey operations, our confidence in Toscotec's ability to successfully complete complex tissue projects on a tight timeframe was a key factor in our decision. At Vajda Papír we select the most advanced and energy efficient technology to manufacture premium tissue quality for our customers and consumers."

**Marco Dalle Piagge, sales director of Toscotec**, comments: "We are very happy to begin an important partnership with Vajda Papír. Toscotec strengthens its position as global leading supplier of turnkey solutions for the tissue industry. Delivering a complete tissue line on a turnkey basis according to schedule, and assuming responsibility

for the achievement of performances for the entire supply requires significant expertise. We are the only tissue machinery manufacturer with nearly 20 years of experience in turnkey projects across 4 continents."

**Matteo Giorgio Marrano, Toscotec sales manager**, says, "With Vajda Papír's order, Toscotec increases its market penetration in Eastern Europe with three major tissue projects sold in the last two years, including two double-width machines. This new line will be equipped with advanced and energy-efficient technology, including Toscotec's shoe press and TT SYD of latest generation, and high-recovery TT Hood."



## Superior drying efficiency for over 60 years.

Toscotec SteelDryers are the cutting-edge technology you need to achieve your maximum drying capacity, increase production and improve operating efficiency. Full-scale customization: we design the size of TT SteelDryers and custom make the rebuild of your machine according to your needs.

Toscotec, world-leading supplier of steel dryers for the paper and board industry.

---

**PRESS BOOK - EDITION 7**



**ASIA & PACIFIC**

Toscotec Paper Machine (Shanghai) Co., Ltd.  
598, Heng'An Road, Gaohang  
200137 Shanghai, PR China

**NORTH AMERICA**

Toscotec North America  
3313 S. Packerland Drive  
De Pere, WI 54115, USA

**ITALY**

Toscotec S.p.A.  
Viale Europa, 317/F  
55012 Marlia, Lucca, Italia